

GOAL
SINGLE CYLINDER
GK725S - GK625S - GK525S



SINGLE CYLINDER

GK725S - GK625S - GK525S



KNITTING HEAD
designed to knit high quality
items and ensure constant
reliability over time

SINKERS CAP
standard terry
or plating

**NEW
ELECTRONICS**
with high
resolution touch
screen display

NEW BASE
designed to increase solidity
and rigidity, allows a more
ergonomic assembling of
components

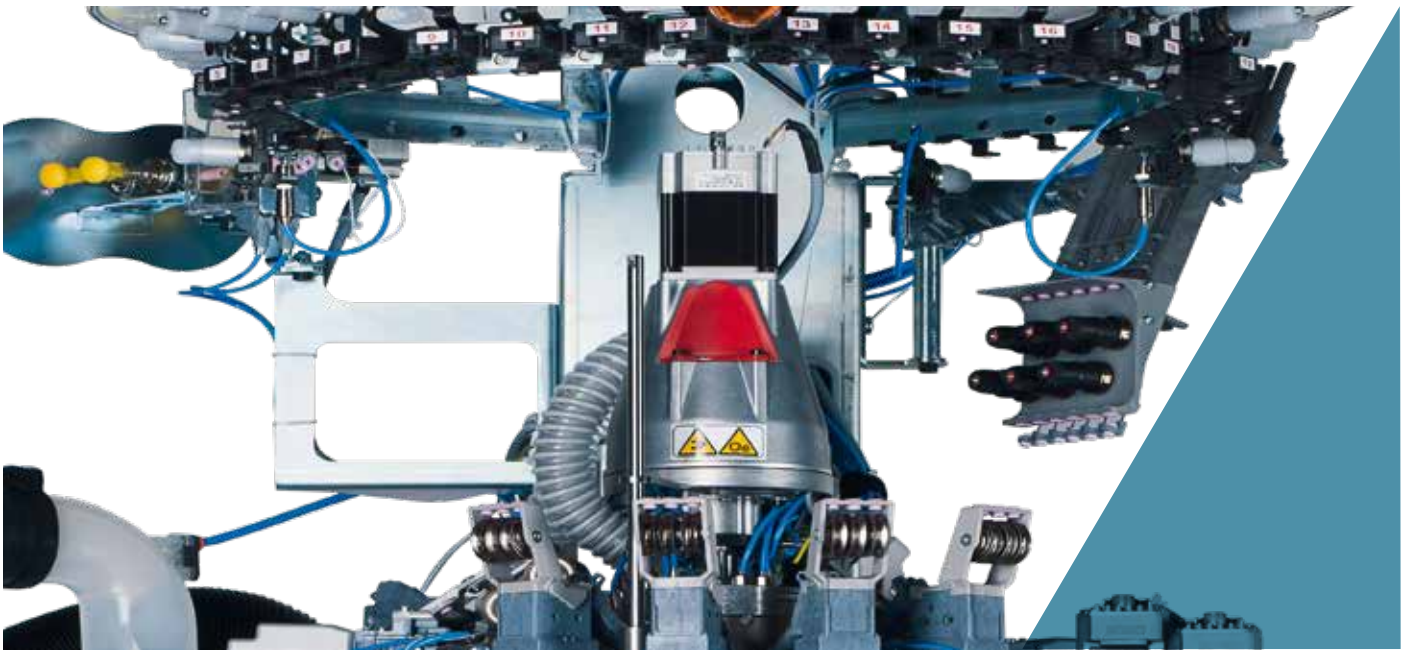

All images in this brochure are indicative and not binding.

SINGLE CYLINDER

GK725S - GK625S - GK525S

Goal Series 2 feeds machines are designed to offer maximum productivity. They are available in different diameters with different numbers of needles. Latest generation electronics provides control and execution of all machine commands. Drawings and articles are created and managed by Digraph 3 Plus software package, which contains a full collection of styles the operator can combine in different ways to obtain the desired results.

- 5 colors pattern on single feed course, plain knit or terry
- Reciprocated heel and toe in different sizes, 3D effects
- 28 yarn fingers
- Rising dial and finger plate with stepping motor
- 9 electronic actuators for needle selection
- Brushless coaxial main motor

MACHINE DIMENSIONS



Length max cm 94.5
Depth max cm 103.3
Height max cm 180

MACHINE WEIGHT



ca. 230 Kg

SINGLE CYLINDER

GK725S - GK625S - GK525S

TECHNICAL DATA

MODEL	CYLINDER DIAMETER	GAUGE	NEEDLE THICKNESS
GK725S	3"1/2	7 1/2 to 14	0.85 - 0.70 - 0.60 mm
GK625S	3"3/4	from 9 to 17	0.85 - 0.70 - 0.60 mm
GK525S	4"	from 6 1/2 to 16	0.85 - 0.70 - 0.60 mm

Above data are indicative and not binding.

STANDARD DEVICES

- Stepper motor electric dial with adjustable height
- Stitch cam feeds 1 and 2 with 3 different heights.
- Motorized sinker cap for sinker pressure and angular position
- High resolution touch screen display
- Yarn sliding sensors guard cleaning device
- Heel yarn recover device with four positions
- 14 color yarn fingers
- 9 yarn fingers on first feed, 6 on second feed
- Yarn creel
- USB port
- Circular yarn cutter with mechanical stop
- 1 yarn finger on inlaid elastic feed
- Stepper motor controlled adjustable suction valve

MAIN OPTIONAL DEVICES

- LGL Eco Power or Eco Compact yarn storage feeder
- Dinema YoYo positive yarn feeders
- Elastic yarn positive feeders, for compression socks
- Dinema Plus elastan positive feeders
- Motorized stitch cams
- Antitwist device
- Footlet device
- G-Flot device
- G-Flot 2 device
- Elastane extra pliers device
- Recover yarn device, 6 positions
- Yarn trimming circular cutter with adjustable speed
- Preparation for storage feeder "Unifeeder 2" by BTR
- Ethernet board for connection to Dinema Nautilus data collector system
- Second elastic yarn finger, on second feed
- Yarn sliding control sensors, Dinema ISPY
- Pneumatic yarn tensioner for covered elastane
- Suction fan

POSSIBLE KNITTING

The standard machine can perform the following knittings

- Mesh, tuck and float stitch, jacquard, 2 feeds, plain knit or terry
- 5 colors pattern plus ground color, mesh, tuck and float stitch, 1 feed, plain knit or terry
- With laid-in elastic: 5 colors pattern plus ground color, tuck and float stitch, 1 feed, plain knit or terry
- With laid-in elastic: mesh, tuck and float stitch, 4 colors pattern plus ground, 1 feed, plain knit or terry
- Laid-in elastic on 2 feeds, that is one course elastic every two knitted course, on plain knit or terry
- With the second elastic yarn finger 4 colors pattern on course plus ground, tuck and float stitch, one feed, plain knit or terry
- With the second elastic yarn finger 3 colors pattern on course plus ground, mesh, tuck and float stitch, one feed, plain knit and terry

SINGLE CYLINDER

GK725S - GK625S - GK525S



NUMBER OF COLORS

Number of colors	5 colors on course plus ground color, one feed
------------------	--

PERFORMANCES

	3" 1/2 3" 3/4 4" CYLINDERS
KNITTING FEATURES	Patterns or selections 300rpm Plain knit without pattern 350rpm
MAXIMUM SPEED	350 rpm

Above data are indicative and not binding.

DISCLAIMER: maximum speed may vary depending on yarn, knitting, lubrication etc

GAUGE

		GAUGE																						
Model	ø	6½	7	7½	8	8½	9	9½	10	10½	11	11½	12	12½	13	13½	14	14½	15	15½	16	16½	17	
GK525S	4"	84	88	96		108 112		116 120		128 132	136	144		156 160		168	176	180	188	192	200			
		Needle thickness 0.85 mm																						
		Needle thickness 0.70 mm											Needle thickness 0.70 mm					Needle thickness 0.60 mm						
GK625S	3"3/4		84	88	96		108	112	116	120 128	132		144		156	160	168		176	180	188	192	200	
		Needle thickness 0.85 mm																						
		Needle thickness 0.70 mm																		Needle thickness 0.60 mm				
GK725S	3"1/2			84	88	96	100		108 112	116	120	128	132		144		156							
		Needle thickness 0.85 mm																						
		Needle thickness 0.70 mm																						

Above data are indicative and not binding.

DISCLAIMER:

All features in the brochure are for information only and subject to change without any prior notice.

For a complete list of available options, please contact Lonati sales network.

The Company accepts no liability for improper use of machinery.

Lonati is recommending needles from
GROZ-BECKERT®

SINGLE CYLINDER

GK725S - GK625S - GK525S

NOISE LEVEL (Maximum noise output for GK series models)

Noise pressure level on reference surface = LPA 79,5 dB - Noise power level = LWA 96,6 dB - Peak= 109,3 dB

LUBRICANTS

Average consumption for 100 dozens= 270 gr. Lonati recommends: Kluber Madol 183 Supreme - Fuchs Trax 16C

GREASE

For seals, bearings etc: Lonati recommends: TechnolubeSeals Damping grease Nyogel 774F-1

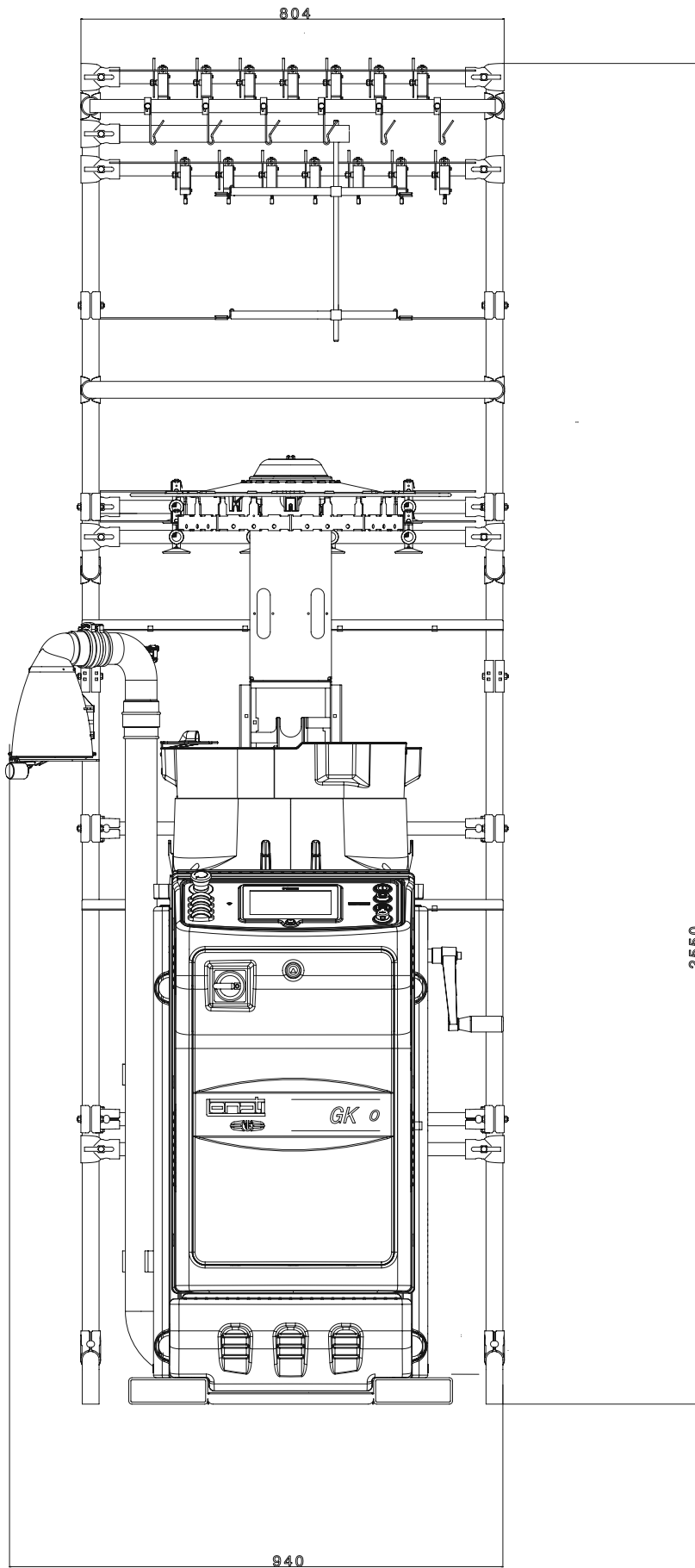

DESCRIPTION	CODE	NR. OF REELS	WEIGHT KG.	NOTES
Yarn creel	G1930040	28	20	Standard version
Yarn creel	G1930041	28	20	Version with BTR sensors

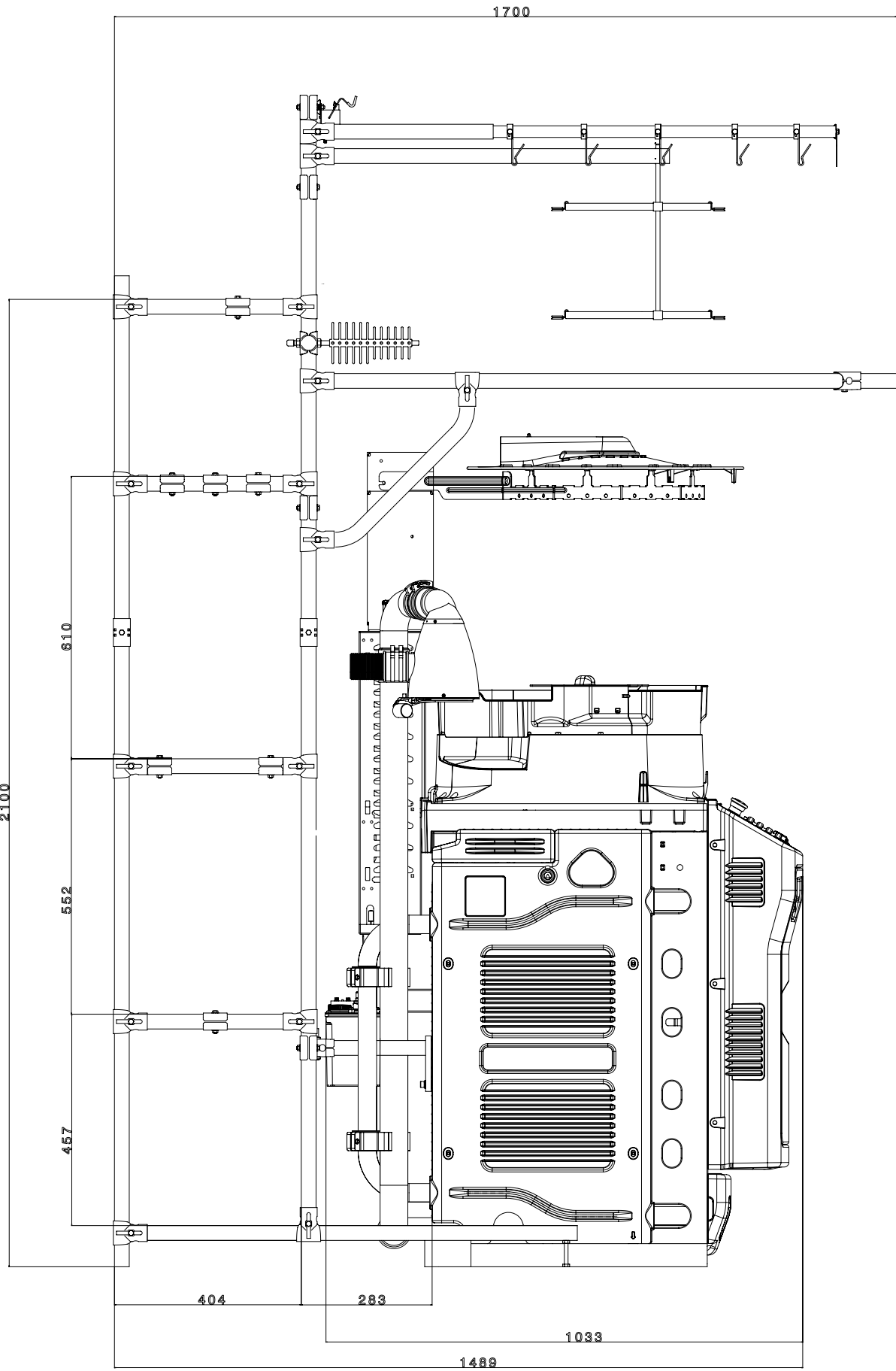

DESCRIPTION	CODE	NR. OF REELS	WEIGHT KG.	NOTES
Yarn creel	G1930040	28	20	Standard version
Yarn creel	G1930041	28	20	Version with BTSR sensors

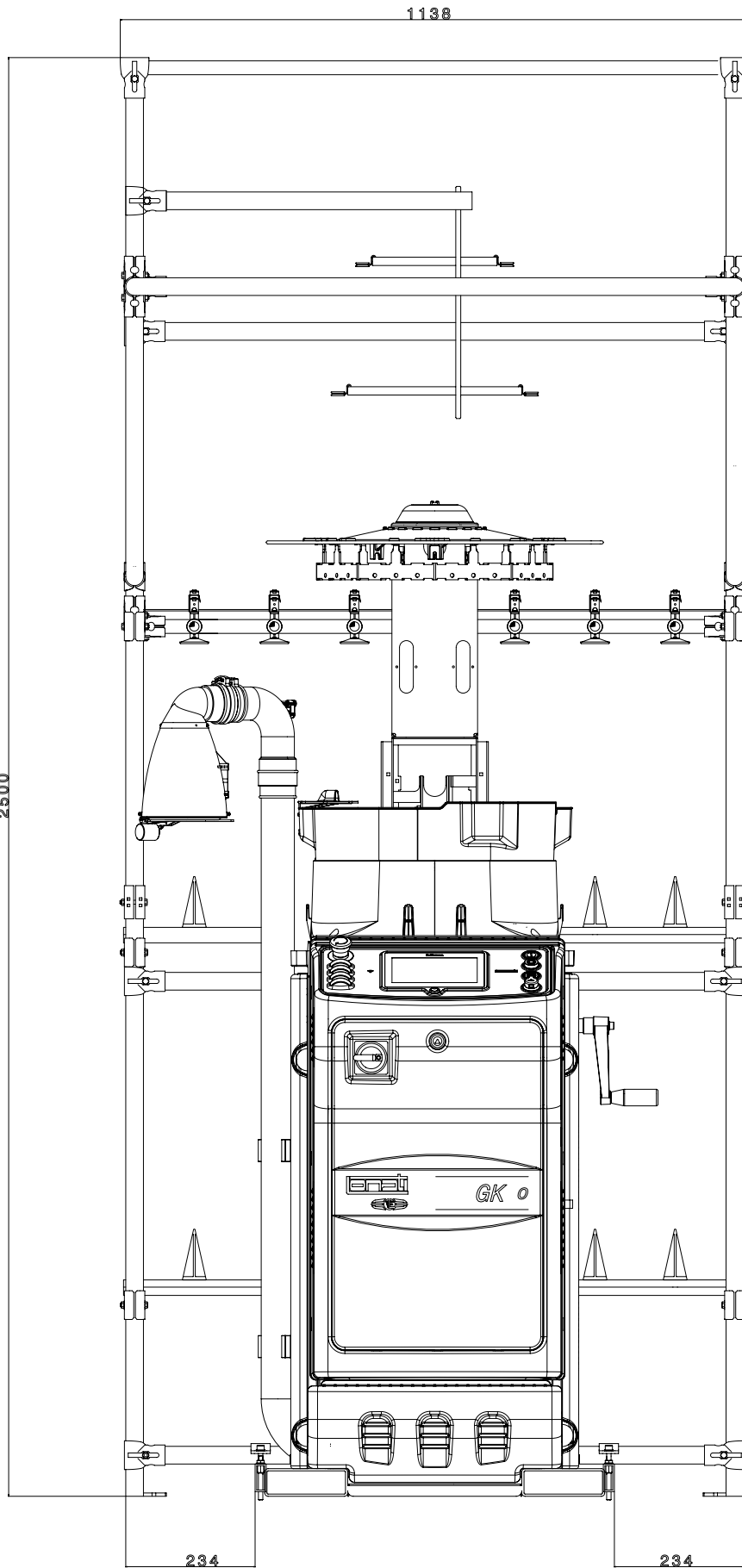

DESCRIPTION	CODE	NR. OF REELS	WEIGHT KG.	NOTES
Yarn creel	G3930061	28	51	Standard version
Yarn creel	G3930062	28	51	Version with BTR sensors

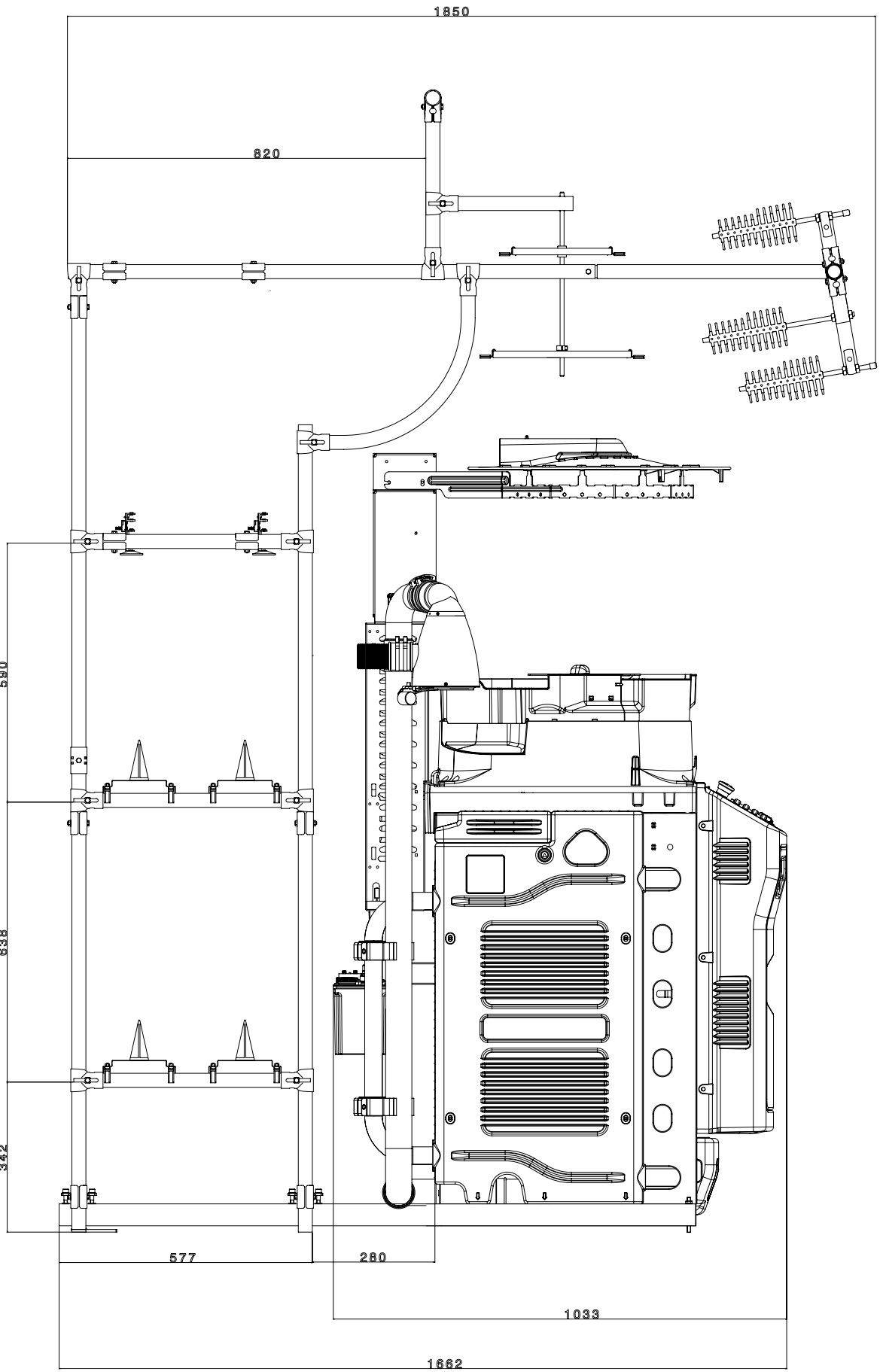

DESCRIPTION	CODE	NR. OF REELS	WEIGHT KG.	NOTES
Yarn creel	G3930061	28	51	Standard version
Yarn creel	G3930062	28	51	Version with BTR sensors

NOTE

GK725S - GK625S - GK525S





LONATI SPA

Via Francesco Lonati, 3 | 25124 Brescia (Italy)
Tel. +39 03023901 | Fax +39 030 2310024
C.F.: 01469680175 | P.iva: 02096730961
info@lonati.com - www.lonati.com